

CAD FILE:

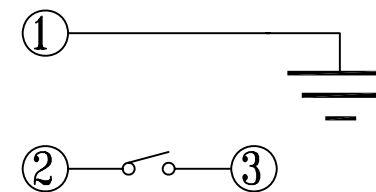

SCHMATIC

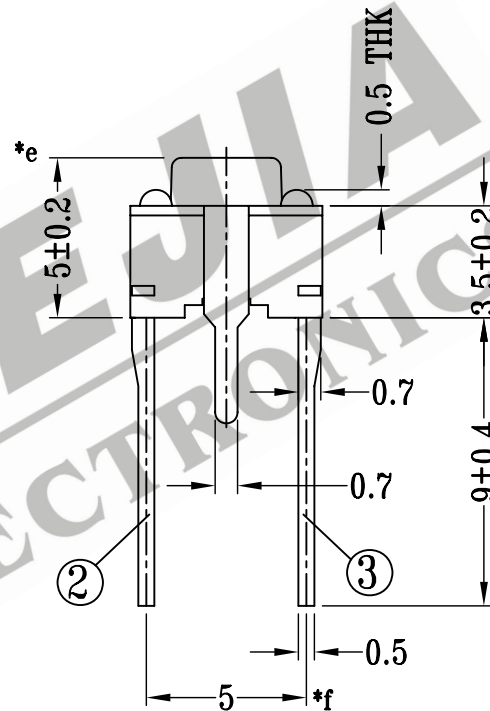
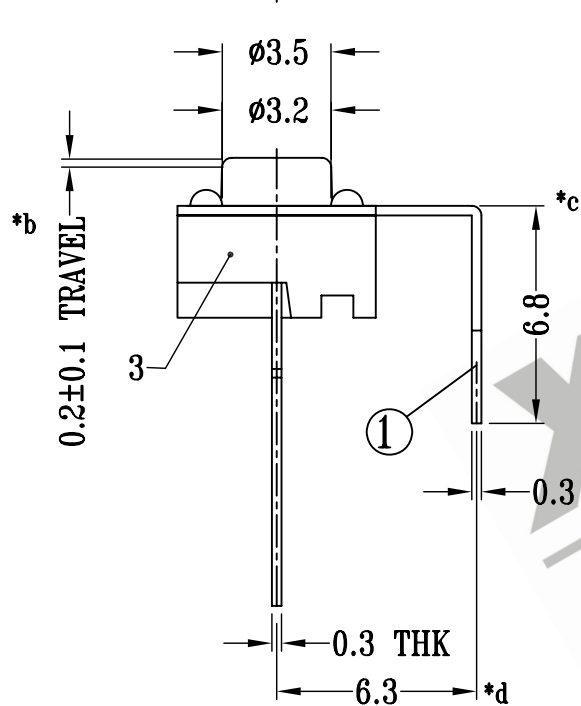
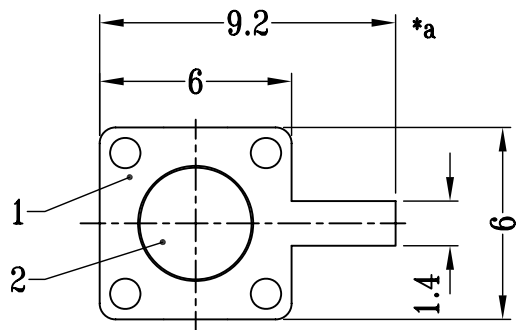
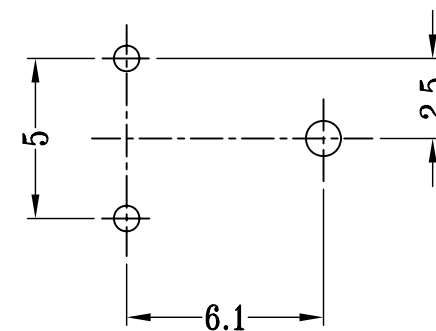

P.C.B LAYOUT

注:带"*"表示关键尺寸(6个)

8					TOLERANCE UNLESS SPECIFIED	SHENZHEN XIEJIA ELECTRONICS CO.,LTD.						
7												
6					WITHIN: 1.5±0.1mm OVER: 1.5±0.2mm	ISSUE	DATE	DESCRIPTIONS OF REVISION		APPD.		
5												
4	CONTACT	PBS	1	Ag CLAD	TITLE : TACT SWITCH			UNIT : mm		DRWG NO.: XJ-DR-TC3303-00		
3	CASE	NYLON+F.G/BRASS STRIP	1	BLACK/Ag PLATED OVER Ni PLATED								
2	KNOB	NYLON+F.G	1	BLACK	MODEL: TC-3303			SCALE: 4:1		DWN.	ZHOUYU	2002-4-17
1	FRAME	ZINC STRIP	1	WASHING						CHK'D	FANGYING	2002-4-17
NO.	PARTS	MATERIALS	Q'TY	FINISH	ALL MATERIALS MUST BE COMPLIANT TO ROHS			APPD.	KANGXINAN	2002-4-17		